

Basic Science In Medicine

SEQUESTRATION OF LEUKOCYTES BY THE ISOLATED PERFUSED RAT LUNG

BAHRAM GOLIAEI, Ph.D., AND JOHN C. SCHOOLEY*, Ph.D.

From the Institute of Biochemistry and Biophysics, University of Tehran, Iran; and the * Environmental Physiology Group, Division of Biology and Medicine, Lawrence Berkeley Laboratory, Berkeley, CA, U.S.A.

ABSTRACT

The sequestration of rat leukocytes and bone marrow cells by the lung vasculature was studied using an isolated perfused rat lung preparation. The passage of latex particles of $7.6 \mu\text{m}$ in diameter and non-hematopoietic cells through the lung blood vessels was also studied. Leukocytes and bone marrow cells were reversibly sequestered from circulation, whereas, latex particles and non-hematopoietic cells were removed irreversibly. Continuous circulation of leukocytes or bone marrow cells results in a steady-state at which circulating cells and the lung reach some kind of equilibrium with no net cell removal by the lung. Further cell removal or release can occur by changing the circulating cell concentration. Removal of Ca^{++} and Mg^{++} from circulating medium decreased the sequestration of leukocytes by the lung. Complement activation is not involved in this process, since whole blood as well as serum free suspension of leukocytes, bone marrow cells or peritoneal cavity neutrophils showed similar patterns of sequestration. The results indicate that cell sequestration by the isolated perfused lung is a physiological process which can be considered as a suitable model of the *in-vivo* sequestration of blood leukocytes by the vascular system of the body. The pattern and the rate of sequestration depends on the cell type, cell concentration in circulation, and chemical factors in circulating medium. The results provide new information about the mechanisms which might be responsible for the sequestration of leukocytes by the lung vasculature in the absence of complement activation.

MJIRI, Vol. 4, No.2, 113-120, 1990

INTRODUCTION

Blood leukocytes are the major component of the body's defense system. Their concentration and distribution throughout the blood vascular network is a key factor in an early and prompt response to any foreign invasion of the body.

Leukocyte infusion therapy has become an impor-

tant step in the management of severe infection in patients with defective leukocyte system.¹ In spite of recent improvement in collection and storage of leukocytes, very little information has been available on the mechanisms controlling the distribution of native and infused leukocytes in the body.

Granulocytes are about equally distributed within the vascular system between a circulating and a marginated population of cells which are in rapid equilibrium.^{10,18,27} In some neutropenic patients, the size of the marginated pool is inversely correlated with the size of the circulating pool.¹⁸ Attempts to elevate

Correspondance: Bahram Goliaei, ph.D. Institute of Biochemistry and Biophysics, University of Tehran, P.O. Box 13145-1384 Tehran, IRAN

Sequestration of Leukocytes by Rat Lung

the concentration of granulocytes significantly in the circulating blood by transfusion of leukocytes have been unsuccessful ($22 \pm 14\%$ yield),^{22,24} presumably because the transfused cells are sequestered within the vasculature of organs such as the lung.^{2,7} The sequestered cells can be recovered in the circulating pool by epinephrine or exercise.⁴ The two processes of margination of leukocytes in the normal situation and sequestration of transfused leukocytes are little understood; the relationship between the two processes is not known. It is not clear whether the mechanism responsible for normal margination is also responsible for sequestration of infused cells or other factors also contribute to the sequestration of infused cells because the actual yield from infusion has always been less than predictions made based on 50% margination.⁸

Studies of the adherence of leukocytes to glass beads^{13,17} and nylon fibers^{19,20} have been made. Although there are some correlations between these *in-vitro* phenomena and clinical observations, such *in-vitro* systems are not useful for studying the nature and mechanism of leukocyte adhesion to vascular endothelium. The adherence of leukocytes to cultured endothelial cells^{9,21} may be more physiological than *in-vitro* adhesion studies using glass or plastic surfaces,

but the surface of cultured cells may differ from the luminal surface of the endothelial cells within an organ. The leukocyte-endothelial interactions have recently been reviewed.¹⁵

We have utilized an isolated perfused rat lung system to study the problem of leukocyte sequestration and margination and suggest that the advantages of the system are: 1) the interaction of cells with the luminal surfaces of the endothelium of the lung *in-vivo* can be quantitated, 2) the three dimensional structure of the lung vasculature is maintained, and 3) morphological studies of sequestration and margination phenomenon in intact endothelium can be readily undertaken.

In this work we studied the sequestration of leukocytes and other non-hematopoietic cells and particles by the isolated perfused rat lung. It is shown that leukocytes, but not latex particles of similar size of non-hematopoietic cells, are reversibly sequestered when they pass through the lung. By continuously circulating leukocytes or bone marrow cells through the lung, the system reached a steady-state at which circulating cells and the lung were in some kind of equilibrium, with no net cell removal by the lung. Changes in circulating cell concentration in this state caused the lung to remove cells from, or release them into circulation. The role of divalent cations on this process was also studied.

MATERIALS AND METHODS

Animals:

Male CD rats (Charles River Co.) of about 350 grams in weight were used in all experiments.

Isolated perfused lung preparation:

The animals were anesthetized by intraperitoneal injections of sodium pentobarbital (Diamond Labs, Inc.), 3.9 mg per 100 g of body weight. Following anesthesia, a tracheotomy was performed by inserting a silicon rubber (silastic tubing) cannula, $0.16 \text{ mm}^{\text{ID}} \times 0.24 \text{ mm}^{\text{OD}}$ (Dow Corning Co.), into the trachea and securing it in place by a ligature. Blood coagulation was prevented by either injecting 1 ml of heparin sodium, 1,000 U.S.P. (Upjohn Co.), through the jugular vein, or by mixing 2 ml of the above heparin with sodium pentobarbital, used for anesthesia, and injecting it intraperitoneally. The diaphragm and rib cage were then incised, exposing the heart and lungs. Respiration was restored immediately after opening the chest cavity by connecting the tracheal cannula to a Harvard respirator, model 680 (Harvard Apparatus Co.), under maximum inflation pressure of 18 cm H_2O and 45 strokes per minute. Stroke volume was adjusted to 3 ml per stroke. Pressure was measured by a Statham pressure transducer, model 5E (Gould Statham Inst.,

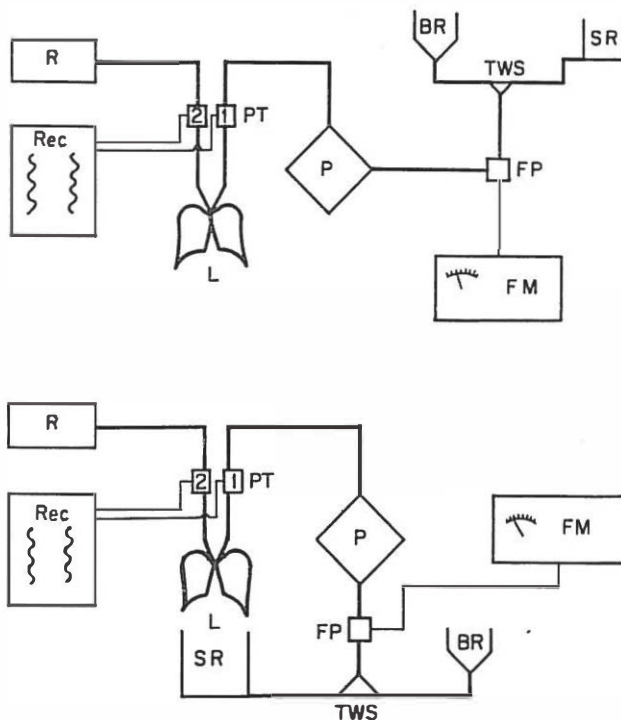

Figure 1. Upper diagram: Single-pass perfusion system. Lower diagram: Continuous-circulation perfusion system. SR: Particle or cell suspension reservoir; BR: Buffer reservoir; TWS: Three-way stopcock; FP: Flow probe; FM: Flow meter; P: Pump; PT-1: Pressure transducer, liquid; PT-2: Pressure transducer, air; L: Lung; R: Reservoir; Rec: Recorder. In the continuous-circulation system cell suspension reservoir is placed directly under the lung so that the lung effluent drips directly into the reservoir and circulates.

Inc.).

The pulmonary artery was cannulated through an incision in the right ventricle, and the cannula (same material and size as used for the tracheal cannula) was secured in place by a ligature with the heart and lungs still intact in the chest cavity. The left atrium was then incised to allow the perfusate to drip out.

Perfusate was pumped through the lung by a Harvard peristaltic pump, model 1203 (Harvard Apparatus Co.), at a flow rate of about 9 ml per minute, with a peak-to-peak pressure of 3-20 cm H₂O. Flow rate measured by a magnetic flow probe, model 300 A (North Carolina Medical Electric Co.) and a square-wave flow meter, model 321 (North Carolina Med. Elec. Co). Perfusion pressure was measured by a Statham transducer, model P23db (Gould Statham Co.). Both the perfusion and respiration pressures were recorded by a HP recorder, model 7402A (Hewlett Packard Co.).

The perfusion and ventilation parameters were chosen as close as possible to the available *in-vivo* values for optimal results.

The heart was totally excised as soon as the pulmonary artery cannula was secured in place; immediately thereafter the lungs were removed from the chest cavity and suspended from the tracheal cannula in ambient air at room temperature. The whole surgical operation, from the moment that the chest cavity was opened to the moment when the lungs were removed, took about 8 minutes.

Perfusates were maintained in two types of water-jacketed glass reservoirs. A funnel shaped reservoir was used for maintenance of cell-free or particle-free buffers and a flat bottom reservoir was used for cell or particle suspensions. The flat bottom is especially useful for placing the reservoir on a magnetic stirrer to constantly and gently stir the cell or particle suspension. The floor of the flat-bottomed reservoir was made flush with the perfusate outlet arm so that cells or particles would not have any barrier on their way out, and a uniform transfer of particles from the reservoir, through the perfusion tubing to the lung, was assured.

The temperature of the perfusates was kept constant at 37°C by circulating water from a variable temperature bath and circulator, model 2095 Masterline (Forma Scientific Co.) through the water jackets around the reservoirs.

Table I. The effect of Ca⁺⁺ and Mg⁺⁺ on the sequestration of neutrophils by the isolated perfused rat lung.

Treatment	Non-Sequestrable Fraction.(%)	n
Control	6.42	(5)
No Ca ²⁺ and Mg ⁺⁺	12.33	(6)

Perfusion:

To wash as much blood as possible out of the lung, it was initially perfused and washed for 10 minutes with one of the following buffers; Dulbecco's medium supplemented with 20 percent fetal calf serum (GIBCO), PBS (Dulbecco's phosphate buffered saline solution, GIBCO), or Hank's balanced salt solution (GIBCO). Only lungs which could be washed clean and white were used for the experiments. Immediately following this initial cleansing, whatever perfusate to be used in the experiment was perfused through the lung:

1. Single-pass perfusion

In this mode, the perfusate was passed only once through the lung. The pulmonary venous effluent was then collected and treated as desired (Fig. 1a). The experimental set-up was a modification of Pickett's method.²³

2. Continuous-circulation perfusion

In this mode, suspensions of hematopoietic cells with desired concentrations was circulated through the lung for the desired period. Samples were taken either from the pulmonary venous effluent drops or from the reservoir at various time after initiation of perfusion (Fig.1b). The experimental set-up was a modification of Bassett's method.⁶

Cell and Particle Suspensions

Four kinds of cell populations: whole blood, peritoneal cavity neutrophils, bone marrow cells, rat rhabdomyosarcoma (R1) cells and a suspension of latex

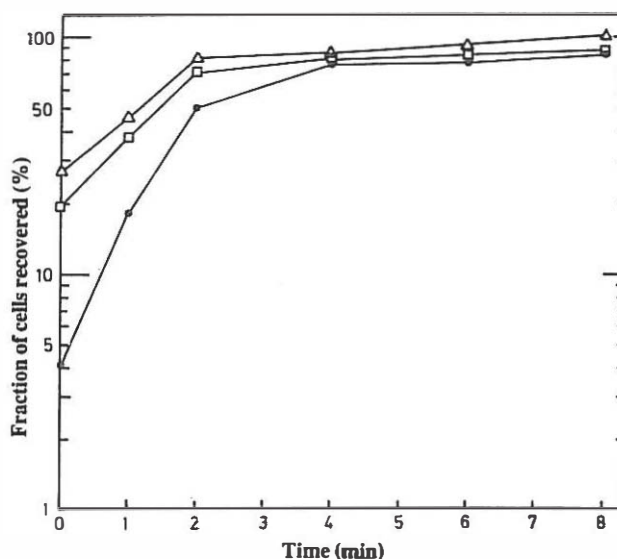

Figure 2. Sequestration of blood leukocytes by the isolated perfused lung. Rat whole blood was perfused in the single-pass mode through the lung. Average leukocyte concentration and differentials were 13.6×10^6 cells per ml, 50% neutrophils, and 70% mononuclears (lymphocytes and monocytes). The percentage of cells in the initial perfusate that recovered in lung effluent is plotted versus the time of perfusion. □ blood leukocytes; ● neutrophils; △ mononuclears. Mean \pm SEM of duplicate measurements.

Sequestration of Leukocytes by Rat Lung

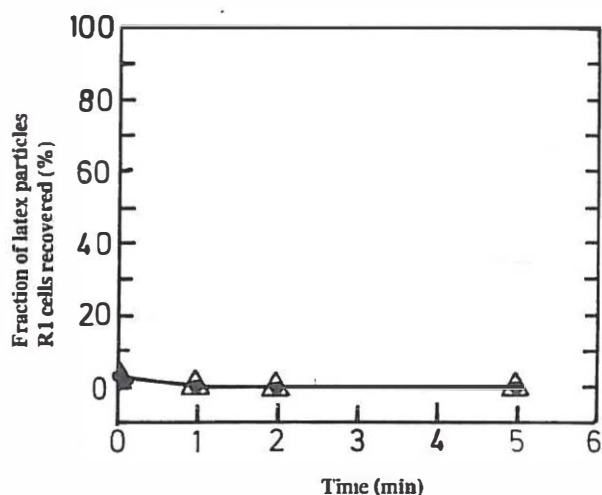

Figure 3. Sequestration of latex particles of $7.6\ \mu\text{m}$ diameter (\bullet) and R1 cells (Δ) by the isolated perfused rat lung. Suspensions of latex particles with concentrations 3.7×10^6 and 9.3×10^6 particles per ml or R1 cells with concentrations of 1.82×10^6 or 0.9×10^6 cells per ml were perfused in the single-pass mode through the lung. The percentage of particles or cells in the initial perfusate that are recovered in the lung effluent is plotted versus the time of perfusion.

particles were used in these experiments. All glasswares were siliconized when handling various cell suspensions or whole blood.

1. Whole Blood

Whole blood was collected by bleeding rats through the vena cava with a heparinized 20 ml plastic syringe.

2. Bone Marrow

Bonemarrow from two femurs and tibias of a rat was suspended in Dulbecco's medium supplemented with 20 percent fetal calf serum (GIBCO). The marrow was gently passed through successively smaller needles (gauge 19 to 27) to produce a single cell suspension (a total of ten passages for all preparations). Cell concentration and suspension volume was adjusted to the desired values.

3. Peritoneal Cavity Neutrophils

Rats were injected with 20 ml of 1% glycogen in saline. Four hours later animals were sacrificed and their peritoneal cavity was washed with PBS. Cells collected were washed with PBS and differentials were made with Wright-Giemsa staining. Always more than 95% were neutrophils with macrophages constituting the majority of the other 5%.

4. R1 cells

R1 cells were kindly supplied by Dr. T. Tenforde at Lawrence Berkeley Lab. The cells were suspended in the Dulbecco's medium with or without fetal calf serum at the desired concentrations.

5. Latex Particles

Latex particles (Dow Chemical Co.) with a diameter of 7.6 ± 2.3 were suspended in Dulbecco phosphate buffered saline (GIBCO) to the desired concen-

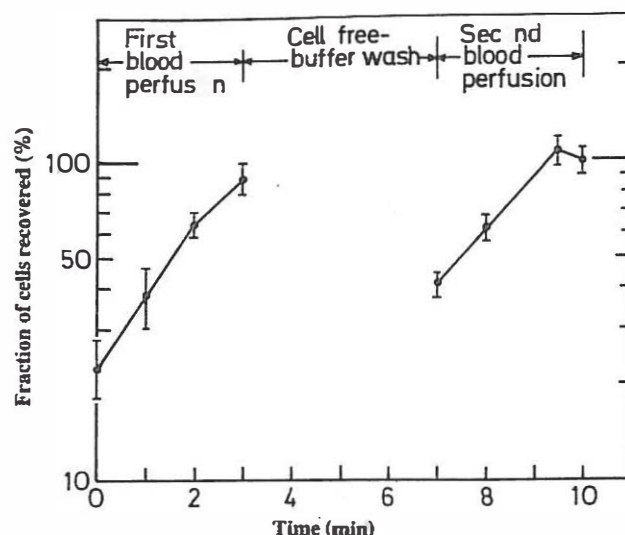

Figure 4. Sequestration of blood leukocytes by the isolated lung in the double-perfusion experiment. Lung was perfused with whole blood (7.01×10^6 leukocytes per ml) for four minutes and then with cell-free buffer for another four minutes to remove and wash previously perfused blood. Finally the lung was again perfused with blood. The percentage of leukocytes in the initial blood perfusate that are recovered in the lung effluent is plotted versus the time of perfusion. Mean \pm SEM of duplicate experiments.

tration. This suspension was used for single-pass experiments. In all suspensions using artificial medium, the pH was adjusted to 7.3-7.4.

Cells and latex particles were counted in a hemocytometer. At least two counts were done on each sample. Cell viability was measured by the Eosin Y exclusion test.

RESULTS

There was no detectable retention of cells by the perfusion system without the lung, in either single-pass or continuous-circulation mode within up to at least two hrs. Also, variations in the administered dose of heparin showed no effect on the experimental results described below.

Single-Pass Perfusion Experiments:

The sequestration of leukocytes by the isolated perfused rat lung was established by single passage of 90ml freshly collected rat blood through an isolated rat lung. Samples of blood were collected from the lung effluent drops at intervals and their leukocyte concentrations and differentials were determined. As shown in Fig. 2, the fraction of cells which can pass through the lung without retention is low at initial moments, but then increase smoothly and reach a plateau within four to five minutes of perfusion. This specific pattern of cell sequestration was observed with all hematopoietic

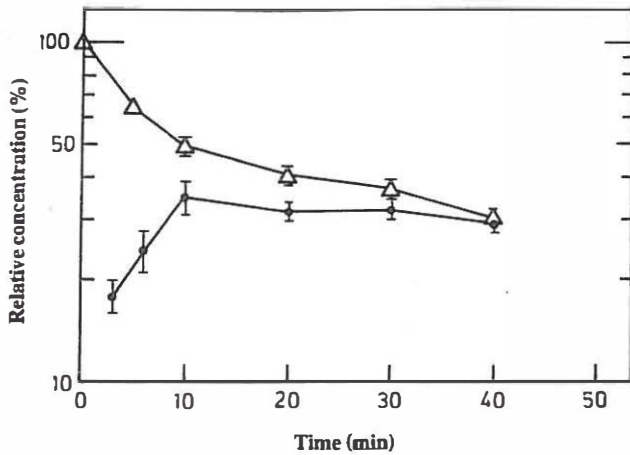

Figure 5. Sequestration of bone marrow cells by the isolated perfused lung in the continuous-circulation mode. Initial concentration of suspension was 9×10^6 cells per ml. Relative concentration of lung effluent, ●, (concentration of cells in lung effluent/initial concentration of circulating suspension $\times 100$), and of reservoir, △, (suspension cell concentration/initial concentration of circulating suspension $\times 100$) are plotted versus the time of circulation. Mean \pm SEM of triplicate measurements.

cells examined. Since the behaviour of various sub-populations of blood cells were similar, even though quantitative differences were evident (Fig. 2), the data presented in all other experiments are those of blood leukocytes or nucleated bone marrow cells.

To investigate whether the cell sequestration observed is a mechanical property of the isolated lung or not, the above experiment was repeated using R1 cells or suspension of latex particles with $7.6 \pm 2.3 \mu\text{m}$ diameter. Two suspensions with concentrations of 3.7×10^6 and 9.3×10^6 particles per ml and two suspensions of R1 cells with concentrations of 1.82×10^6 and 0.92×10^6 cells per ml were perfused through different lungs. In every case, particles and R1 cells were almost totally retained by the lungs (Fig. 3).

Since it was possible that the specific pattern of cell sequestration by the isolated lung might be due to gradual death and loss of function of the lung preparation, the following double-perfusion experiment was performed. Isolated lungs were perfused with whole blood for three minutes. At this time, blood was replaced with PBS as the perfusate, and the perfusion was continued for another four minutes, which washed the lungs clean white. These lungs were then immediately perfused with fresh whole blood for three more minutes. Results are indicated in Fig. 4. With the first blood perfusion the lung removes leukocytes; the fraction of cells which can pass through the lung increases to about 100% by the third minute of perfusion. Dulbecco's PBS introduced into system as the perfusate this time washes the lung clean white within the next four minutes of perfusion. With the next round

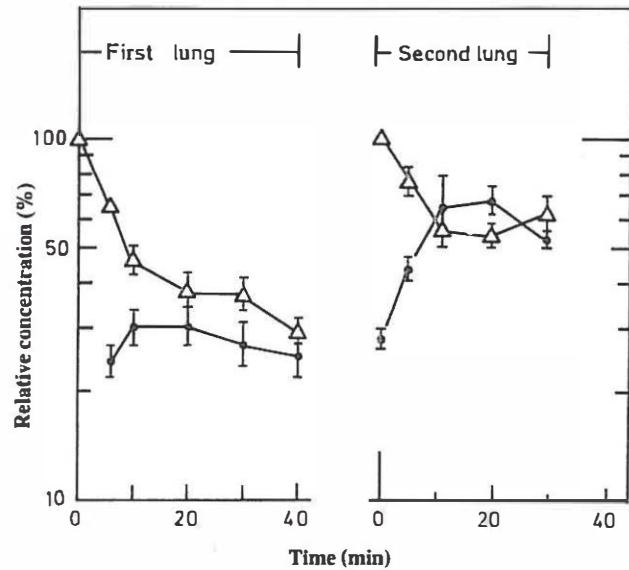

Figure 6. Sequestration of bone marrow cells in a double-lung continuous circulation experiment. Initial concentration was 8.8×10^6 cells per ml. The suspension was circulated for 40 minutes. Then the lung was replaced with another one and circulation was resumed and continued for another 40 minutes. For each lung, relative concentration of the lung effluent, ●, (concentration of cells in the lung effluent/initial concentration of circulating suspension corresponding to the same lung $\times 100$), and of reservoir, △, (cell concentration in circulating suspension/initial concentration of circulating suspension corresponding to the same lung $\times 100$) is plotted versus the time of perfusion for each lung. Mean \pm SEM of triplicate experiments.

of blood perfusion the lung removes the cells in a similar manner as with the first blood perfusion. It is clear that the lung has not lost its capacity of sequestering leukocytes passing through it.

Continuous-Circulation Experiments:

The above experiments already establish that leukocyte sequestration by the lung is not a mere mechanical property or behavior of the isolated lung, however, several questions remain open: (I) Is the sequestration of leukocytes by the isolated lung a reversible phenomenon? (II) Is the sequestration a property of a special group of cells in blood or bone marrow, or are variations in the stickiness of a special group of cells responsible for their sequestrations? (III) What is the relationship between the sequestration capacity and behaviour of the lung and the cell concentrations circulating through it? (IV) What is the effect of divalent cations on leukocyte sequestration by the lung.

To answer these questions the continuous-circulation perfusion set up of Fig. 1b was used. Bone marrow suspensions, whole blood, or specific cell sub-populations of leukocytes yielded similar results with quantitative differences; therefore, only results obtained with bone marrow suspensions are shown in

Sequestration of Leukocytes by Rat Lung

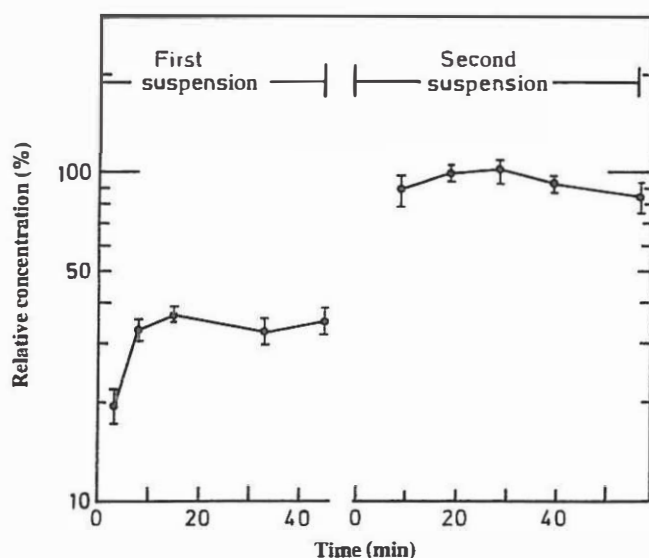

Figure 7. Response of the isolated perfused lung at the steady-state to changing circulating suspension with another suspension at the same concentration. First suspension had a concentration of 8×10^6 cells per ml. The steady-state concentration of the system was 2.7×10^6 cells per ml. After about 45 minutes of perfusion this suspension was replaced with another one with the concentration of 2.1×10^6 cells per ml, and circulation was resumed for another 40 minutes. Relative concentration of lung effluent (cell concentration in lung effluent/initial concentration of the corresponding circulating suspension $\times 100$) was plotted versus the time of perfusion for each suspension. Mean \pm SEM of duplicate experiments.

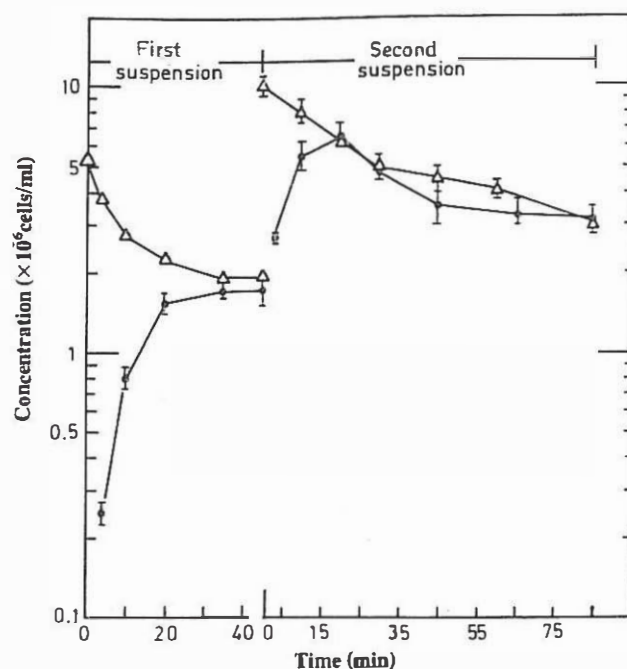

Figure 8. Response of the isolated-perfused rat lung at the steady-state to changing circulating suspension with another suspension of higher concentration. Cell concentration in lung effluent, ● and in circulating suspension reservoir, Δ is plotted versus the time of perfusion for each suspension. Mean \pm SEM of duplicate measurements.

the following experiments.

Reversibility of cell sequestration by the isolated lung was examined by circulating 70 ml of bone marrow cell suspension with initial concentration of 9×10^6 cells per ml through the lung in the continuous-circulation set-up. The lung continuously removed cells from circulation for the first 10-15 minutes of perfusion, after which the system reached a steady state, at which there was no net removal of cells by the lung. The steady state concentration of circulating cells in the suspension was not zero but about 3.6 ± 10^6 cells per ml. This value depended on the initial concentration of the suspension (see also Fig. 7, 8 and 9). If the lung had removed the cells irreversibly, it would have depleted the circulating suspension from its cells in a short time; there would have been no steady-state.

The answer to the second question was provided by performing a double-lung continuous-circulation perfusion experiment (see Fig. 6). Here, a bone marrow suspension (8.9×10^6 cell per ml) was circulated through an isolated lung for about 40 minutes, long enough for the system to reach the steady-state. If the cells circulating in the lung in the steady-state are non-sequestrable cells (for any reason), then perfusing and circulating them through another isolated lung should not result in any net cell removal. At the steady-state the lung in the system was replaced with another freshly isolated and perfused lung of similar

size. The second lung removed cells very much similar to the first lung, indicating that cells remaining in circulation at the steady-state were not non-sequestrable cells.

The significance of the steady-state concentration of circulating cells and the ability of the lung to remove them from or release them into the circulation and criteria of the decision to remove or to release cells was established by the following experiments. If at the steady-state the lung with cells attached to its vasculature reached some kind of equilibrium with circulating cells, then, replacing the circulating suspension and its cells without changing their concentration should not disturb the steady state. Results of such an-experiment is shown in Fig. 7. Here, the first bone marrow suspension with the concentration of 8×10^6 cells per ml was circulated for 40 minutes through an isolated lung. The system reached the steady-state with a concentration of 2.7×10^6 cells per ml. At this time, this suspension was replaced with another suspension of bone marrow cells with the concentration of 2.1×10^6 cells per ml. No net removal of cells from this suspension occurred.

When at the steady-state, the circulating suspension was replaced with a fresh suspension with a concentration different from the steady-state concentration, then one of two things occurred; if the second suspension concentration was higher than steady-state, then the lung removed cells from the new suspension until

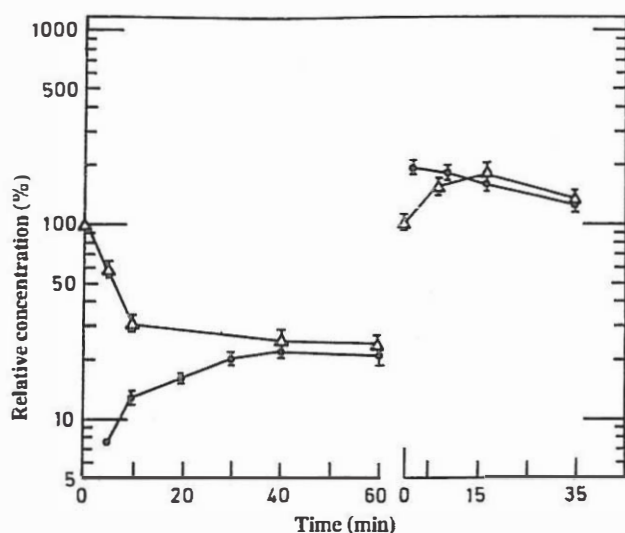

Figure 9. Response of the isolated-perfused lung at the steady-state to changing circulating suspension with another suspension of lower concentration. Initial cell concentration in the first suspension was 15.8×10^6 cells per ml. The steady-state concentration was 3.4×10^6 cells per ml. The replacing suspension had the initial concentration of 1.2×10^6 cells per ml. The relative concentration of the lung effluent, ● (lung effluent cell concentration/initial cell concentration of the corresponding suspension $\times 100$) and of circulating suspension reservoir, Δ, (suspension cell concentration/corresponding initial cell concentration $\times 100$) are plotted versus the time of perfusion of each suspension. Mean \pm SEM of duplicate measurements.

another steady-state was reached by the system. In this case, shown in Fig. 8, the initial concentration of the first suspension was 53×10^6 cells per ml. It was circulated for 50 minutes, and the system reached the steady-state with the concentration of 1.8×10^6 cells per ml. At this point, the circulating suspension was replaced with a fresh suspension of bone marrow with a concentration of 10×10^6 cell per ml, higher than the steady-state concentration. The lung removed cells from this suspension until the system reached a new steady-state with a concentration of about 3×10^6 cells per ml within fifty minutes.

On the other hand, if replacing suspension had a lower concentration than the steady-state one, then the lung released some cells into the circulation. This is demonstrated in Fig. 9, in which initial concentration of the first suspension was 15.8×10^6 cells per ml. After about 70 minutes of circulation the system reached the steady-state with a concentration of 3.4×10^6 cells per ml. The circulating suspension was replaced with the new suspension with a concentration of 1.2×10^6 cells per ml, lower than the steady-state concentration. The lung released cells into the circulation and within 30 minutes the system reached a new steady-state with a concentration of about 2×10^6 cells per ml. The results of this experiment also provide additional support for the reversibility of the sequestration phenomenon.

The effect of Ca^{++} and Mg^{++} on the sequestration

of leukocytes by the lung is shown in Table I. This was examined by passing through an isolated perfused lung, a suspension of peritoneal cavity neutrophils in a Ca^{++} and Mg^{++} free Dulbecco's medium (GIBCO). The total number of cells in the suspension was adjusted to 36×10^6 cells in 40 ml of the medium before perfusion. The lung effluent was completely collected, and the total number of neutrophils was determined. The non-sequestrable fraction of cells was determined as the ratio of the total number of neutrophils in the effluent to the total number of neutrophils before perfusion. In the absence of Ca^{++} and Mg^{++} the non-sequestrable fraction increased significantly (92.34%, $p < 0.05$) over the controls.

DISCUSSION

The *in-vitro* sequestration of leukocytes by the lung has been described by several investigators.^{2,10,11,28} The isolated perfused lung offers several advantages in studying interactions of leukocytes with lung vasculature because, in contrast to *in-vitro* studies with intact animal, interactions with other vascular beds are eliminated, the rate of perfusion can be regulated, the input and output of cells in the system can be readily measured, and the chronological pattern and kinetics of sequestration can also be studied. Our studies with this system indicate that interactions of leukocytes with lung vasculature is a physiological process.

Four possible mechanisms can be conceived for observed patterns of cell sequestration by the isolated lung from perfused blood or bone marrow suspensions: 1) opening of lateral vascular shunts of larger diameter, 2) the gradual death and loss of function of the isolated perfused lung, 3) changes in the stickiness of cells or selective removal of sequestrable cells, and 4) physiologic attachment of cells to the sites of sequestration in the lung vasculature.

The first possibility has been refuted by others.²⁵ Our results of perfusing the lung with latex particles or R1 cells also indicate this simple mechanical view is not correct. The gradual death and loss of function of the perfused lung can also be refuted by our results and work of others. The useful life of an isolated perfused lung in terms of various physiological and biochemical parameters has been determined to be about 1.5-2.5 hrs.^{12,14,26} Although the duration of our single-pass or continuous-circulation perfusion experiments is within this period, results of our double-perfusion experiment also provides additional support against this possibility.

Factors that change the stickiness of neutrophils *in-vivo* and cause their sequestration by the lung^{2,7,11,18} or their release into circulation⁴ have been described. We have been careful to avoid any procedure which

Sequestration of Leukocytes by Rat Lung

might activate complement network when perfusing whole blood. Also, since similar results to that of whole blood perfusion are observed when bone marrow suspension or suspension of neutrophils from the peritoneal cavity are being perfused, sequestration patterns observed could not be due to increased stickiness of neutrophils due to complement activation. Besides, the double-lung perfusion experiment provides unequivocal support against selective removal of sequestrable cell sub-populations by the isolated lung.

The reversibility of leukocyte sequestration *in-vivo* by the lung has been documented.³ Results of our continuous circulation experiments also clearly indicate a reversible nature for leukocyte sequestration by the isolated lung (see Figs. 5 and 9).

REFERENCES

1. Alavi JB, Djcrassi I, Evans AE, et al: A randomized clinical trial of granulocyte transfusions for infection in acute leukemia. *N Engl J Med* 296: 706, 1977.
2. Ambrus CM, Ambrus JL: Regulation of the leukocyte level. *Ann NY Acad Sci* 77: 445, 1959.
3. Ambrus CM, Ambrus JL, Johnson GC, et al: Role of the lungs in regulation of the white blood cell level. *Am J Physiol* 179: 33, 1954.
4. Athens JW, Habb SO, Mauer AM, et al: The total blood circulating and marginal granulocyte pools and the granulocyte turnover rate in normal subjects. *J Clin Invest* 40:989, 1961.
5. Atherton A, Born GVR: Quantitative investigation of the adhesiveness of circulating polymorphonuclear leukocytes to blood vessel walls. *J Physiol* 222: 447, 1972.
6. Bassett DJ P, Fisher AB: alterations of glucose metabolism during perfusion of rat lung with paraquat. *Am J Physiol* 234: 653, 1978.
7. Bierman HR, Kelly KH, Cordes FL: The sequestration and visceral circulation of leukocytes in man. *Ann NY Acad Sci* 59: 850, 1955.
8. Boggs DR: Transfusion of neutrophils as prevention or treatment of infection in patients with neutropenia. *N Engl J Med* 290: 1055, 1974.
9. Boxer LA, Allen JM, Schmidt M, et al: Inhibition of polymorphonuclear leukocyte adherence by prostacycline. *J Lab Clin Med* 95: 672, 1980.
10. Cartwright GE, Athens JW, Wintrobe MM: The kinetics of granulopoiesis in normal man. *Blood* 24: 780, 1964.
11. Craddock PR, Fehr J, Brigham KL, et al: Complement and leukocyte-mediated pulmonary dysfunction in hemodialysis. *N Engl J Med* 296: 769, 1977.
12. Fisher AB, Dodici C, Linsak J: Perfusate composition and edema formation in isolated rat lungs. *Exp Lung Res* 1:13, 1980.
13. Garvin GE: Factors effecting the adhesiveness of human leukocyte and platelets *in vitro*. *J Exp Med* 114:51, 1961.
14. Gassenheimer IN, Rhoades RA: Influence of forced ventilation on substrate metabolism in the perfused rat lung. *J Appl Physiol* 37: 224, 1974.
15. Harlan JM: Leukocyte-endothelial interactions. *Blood* 65: 513, 1985.
16. Hopen G, Schreiner A: Retention in glass bead columns as a measure of leukocyte adhesiveness. I. Influence of sample size and erythrocyte sedimentation. *Scand J Haematol* 22: 219, 1979.
17. Hopen G, Schreiner A: Retention in glass bead columns as a measure of leukocyte adhesiveness. II. Influence of platelets and erythrocytes. *Scand J Haematol* 22: 226, 1979.
18. Joyce RA, Boggs DR, Hasiba U, et al: Marginal neutrophil pool size in normal subjects and neutropenic patients as measured by epinephrine infusion. *J Lab Clin Med* 88: 614, 1976.
19. MacGregor, RR, Macarak EJ, Kefalides NA: Comparative adherence of granulocytes to endothelial monolayers and nylon fibers. *J Clin Invest* 61: 97, 1978.
20. MacGregor RR, Macarak EJ, Kefalides, NA: Comparative adherence of granulocytes to endothelial monolayers and nylon fibers. *J Clin Invest* 61: 97, 1978.
21. Pearson JD, Carleton J, Beesley JE, et al: Granulocyte adhesion to endothelium in culture. *J Cell Sci* 38: 225, 1979.
22. Perry S: Clinical use of leukocyte preparations. In: Williams WJ, Beutler E, Erslev AJ, Rundles RW (eds). *Hematology*, New York: McGrawHill Book Co, 1321, 1972.
23. Pickett RD, Anderson NW, Orton TC, et al: The pharmacodynamics of 5-hydroxytryptamine uptake and metabolism by the isolated perfused rabbit lung. *J Pharmacol Exp Ther* 194: 545, 1975.
24. Price TH, Dale DC: Neutrophil transfusion: effect of storage and of collection method on neutrophil blood kinetics. *Blood* 51: 789, 1978.
25. Ring GC, Blum AS, Karbatov T, et al: Size of microspheres passing through pulmonary circuits in the dog. *Am J Physiol* 200: 1191, 1961.
26. Shaw ME, Rhoades RA: Substrate metabolism in the perfused lung: response to changes in circulating glucose and palmitate levels. *Lipids* 12: 930, 1977.
27. Vejlsens G: The distribution of leukocytes in the vascular system. *Acta Pathol Microbiol Scand (Suppl)* 33: 1939.
28. Weisberger AS, Guyton RA, Heinle RW, et al: The role of the lungs in the removal of transfused lymphocytes. *Blood* 6:916, 1951.