



Cost-Effectiveness Rivaroxaban versus Enoxaparin for Prevention of Venous Thromboembolism after Knee Replacement Surgery in Iran

Ali Abutorabi¹, Marjan Haj Ahmadi¹, Saeed Bagheri Faradonbeh², Asma Rashki Kemmak^{3*}, Vahid Alipour¹

Received: 23 Apr 2022

Published: 11 Mar 2023

Abstract

Background: The highest risk of developing venous thromboembolism (VTE) is seen in patients who have undergone orthopedic surgery. One of the most common methods to reduce the risk of thromboembolism in these patients is anticoagulant prophylaxis. Rivaroxaban is one of the anticoagulants that has a lower cost than other anticoagulants and has a significant effect on people's quality of life as it is edible. The study aimed to determine the cost-effectiveness of rivaroxaban as compared with enoxaparin for venous thromboembolism prophylaxis in knee replacement patients in Iran.

Methods: It was a quantitative and economic evaluation study with a cost-effectiveness approach and an applied study because its results could be used directly for policy-making and decision-making in the health system. The study was conducted in 2019 and 2020. This study considered the health system perspective. The study population included all knee replacement patients. The sample included 203 patients referred to Shafa Yahyaieian Hospital and 300 patients referred to Rasoul Hospital in Tehran. The study was conducted in two steps. A systematic review of studies was conducted in the first step. The CHEERS checklist was used to evaluate the quality of the studies in the systematic review. The EQ-5D questionnaire was used in the second step to calculate the QALY, and the cost collection form was used to calculate the direct medical cost. The data were analyzed through a decision tree, and Stata and Tree age pro softwares were the analysis tools. Also, according to the per capita GDP index for Iran in 2018, the incremental cost-effectiveness threshold was considered to be \$10,000.

Results: The results of this study showed that during the prophylaxis period, rivaroxaban was one and a half times less costly than enoxaparin. Quality of life in uncomplicated conditions were 0.85 QALY for rivaroxaban and 0.69 QALY for enoxaparin. Based on the results of this study, the cost of rivaroxaban during the prophylaxis was \$ 160.97 and the quality of life was 0.85 QALY and the cost of enoxaparin was \$ 276.07 and the quality of life was 0.69 QALY. The cost difference between the two interventions was \$ 115.09 and the outcome difference was 0.16 QALY. The incremental cost-effectiveness ratio was \$ 189.40 for rivaroxaban and \$ 416.28 for enoxaparin. According to the results of this study, rivaroxaban reduced the duration of hospitalization by an average of 2 days in asymptomatic patients (prophylaxis period) compared to enoxaparin.

Conclusion: Rivaroxaban, an oral medication, reduced costs and increased the quality of life in people undergoing knee replacement surgery compared with an enoxaparin injection vial. This drug was less costly for the patient and health systems and its use was cost-effective as a thromboprophylaxis drug following knee replacement surgery.

Keywords: Cost-Effectiveness, Rivaroxaban, Enoxaparin, Venous Thromboembolism, Knee Replacement

Conflicts of Interest: None declared

Funding: This study was part of a Ph.D. thesis supported by the Iran University of Medical Sciences (IUMS/SHMIS with Grant no: 98-2- 37-15593 and with ethical code IR.IUMS.REC.1398.534).

***This work has been published under CC BY-NC-SA 1.0 license.**

Copyright© Iran University of Medical Sciences

Cite this article as: Abutorabi A, Haj Ahmadi M, Bagheri Faradonbeh S, Rashki Kemmak A, Alipour V. Cost-Effectiveness Rivaroxaban versus Enoxaparin for Prevention of Venous Thromboembolism after Knee Replacement Surgery in Iran. *Med J Islam Repub Iran.* 2023 (11 Mar);37:20. <https://doi.org/10.47176/mjiri.37.20>

Corresponding author: Dr Asma Rashki Kemmak, rashkika2@mums.ac.ir

1. Health Management and Economics Research Center, School of Health Management and Information Sciences, Iran University of Medical Sciences, Tehran, Iran
2. Department of Health Services Management, School of Health, Ahvaz Jundishapur University of Medical Sciences, Ahvaz, Iran
3. Department of Pharmaceutical Control, School of Pharmacy, Mashhad University of Medical Sciences, Mashhad, Iran

↑What is “already known” in this topic:

Venous thromboembolism (VTE), also known as blood clots, is a disorder that includes deep vein thrombosis and pulmonary embolism. Venous thromboembolism (VTE) not only has a major impact on the health and quality of life but also imposes a high cost on the health system of countries.

→What this article adds:

The results of the present study showed that rivaroxaban reduced the cost and increased the quality of life in people undergoing knee replacement surgery. Due to the fact that rivaroxaban was taken orally and did not require constant monitoring, it would cost less for the patient and the health system, and its use as a thromboprophylactic drug after surgery was preferred.

Introduction

Non-communicable diseases are currently the leading cause of death and burden of disease in the world. 60% of deaths in 2000 worldwide were due to non-communicable diseases and are estimated to reach 73% by 2020, so the World Health Organization has made the prophylaxis of these diseases a health priority in developing countries (1).

Venous thromboembolism (VTE) is the third most common vascular disease after coronary artery disease and stroke, which is experienced by two to five percent of people during their lifetime. Thromboembolism is a well-known problem that is associated with significant complications and deaths (3). This disease is an important cause of mortality in a hospital that is largely preventable (4).

Deep vein thrombosis (DVT) and pulmonary embolism (PE), commonly referred to as venous thromboembolism (VTE), impose a heavy burden on countries' healthcare systems (5).

DVT is caused by clot formation in the veins. It mainly occurs in the deep veins of the leg, and the thrombus can be embolized from this site toward the lungs. Less than 10% of venous thrombosis is formed somewhere other than the lower extremities. The annual incidence of this disease is about one to three cases per thousand people in developed countries and it is one of the three causes of cardiovascular mortality along with heart attack and stroke (6).

Pulmonary embolism is the third leading cause of death from cardiovascular disease after coronary artery disease and stroke. It is also the most common cause of preventable death among hospitalized patients. Thousands are admitted to hospitals annually for benign and treatable diseases but die from pulmonary embolism, while death can be avoided if prevented (7).

The most important known risk factors for VTE include aging, previous history of VTE, malignancies, trauma, obesity, pregnancy, varicose veins, superficial thrombophlebitis, hormones, venous catheterizations, and conditions that increase coagulation (8).

Complications of VTE include delay in hospital discharge, readmission, complications of taking anticoagulation, recurrent thromboembolism, death and post-phlebotic syndrome as chronic foot swelling, dermatitis, and leg ulcers (9). The risk of VTE increases dramatically during surgery, especially orthopedic surgeries, great vessel surgery, neurosurgery, as well as cancer. Half of the patients with VTE may experience long-term complications such as swelling, pain, and organ discoloration, and 33% of patients experience a recurrence within the next ten years (10).

About 70% of VTE cases can be asymptomatic. Besides, about 6% of cases of DVT and 12% of cases of PE result in death within one month of diagnosis (11).

In the United States and Europe, the number of people who die from VTE is higher than the total number of people dying from AIDS, breast cancer, prostate cancer, and traffic collision (12). Up to 60% of VTE cases occur during or after hospitalization, which is the most important preventable factor in-hospital deaths (13).

About one million cases of VTE occur annually around the world (13). It is estimated at between 100 and 200 per hundred persons annually in Europe (14). Dutch sources report higher estimates from 16,000 to 20,000 VTE cases and 15,000 to 20,000 PE cases. Its incidence is expected to increase due to changes in the elderly population (15). More than 32,000 cases of hospitalization-related VTE occur annually in the UK, 30,000 cases in Australia (16), and more than 540,000 cases in the United States (17).

In Iran, the outbreak of DVT in patients with pelvic and knee fractures with and without drug prophylaxis is reported to be 9.1% and 25%, respectively. The average annual outbreak of DVT among adult patients in Iran who are at risk of this disease was about 130 to 395 cases per thousand patients in 2012. 526 people in 2010, 1068 people in 2011, and 940 people in 2012 suffered from embolism due to knee replacement surgery (18).

Patients who have undergone orthopedic surgery are more at risk of DVT. Orthopedic injuries from pelvic, femoral, and leg bone fractures have also been identified as high-risk factors for DVT. Studies have shown that thromboembolic problems occur in more than half of major orthopedic surgeries, and 30% of this population may develop pulmonary thromboembolism (PTE). Without prophylactic treatment, DVT may increase up to 70% after elective pelvic surgery and 84% after knee replacement (19).

VTE is the most important factor in reducing the quality of life after knee surgery, which occurs in about two-thirds of patients, especially in the first three weeks after surgery. Also, one-third of those with thromboembolism are exposed to problems such as post-thromboembolic syndrome during the first two years thereafter. Reducing the incidence of thromboembolism after knee replacement surgery is one of the main concerns of orthopedic specialists and health systems (20).

Anticoagulant prophylaxis is used as one of the most common methods of reducing the risk of thromboembolism in these patients. However, the drugs used in this prophylaxis are very diverse (21).

Selecting drug factors is affected by efficacy, safety, side effects (such as renal failure), patient's preference and cost. In patients with further risk factors (such as a history of VTE in the elderly, especially over 75, active cancer or a history of cancer, extensive surgery), greater prophylaxis, in the form of increasing dose or duration of drug action, should be considered. Some of the pharmacological agents currently used to prevent VTE in patients who underwent surgery are standard heparin, antiplatelet agents, low molecular weight heparin, vitamin K antagonists, fondaparinux, and newer oral anticoagulants, Rivaroxaban, Dabigatran, and Apixaban.

It was previously more common to use injectable anticoagulants such as heparin and enoxaparin. However, the use of these anticoagulants has been minimized due to the unpleasant method of use (injection) and the need for constant monitoring. The use of oral anticoagulants such as rivaroxaban has currently become more common. The use

Table 1. Probabilities of events

Expected values of probabilities	Expected value	Reference
Prophylaxis with Rivaroxaban		
Major bleeding	0.0057	Lassen et al (25), turipe et al (25)
VTE	0.0959	Lassen et al (25), errikson et al (26)
DVT	0.9988	Lassen et al (25), turipe et al (25)
PE	0.006	Lassen et al (25), turipe et al (25)
Prophylaxis with Enoxaparin		
Major bleeding	0.0057	Lassen et al (25), turipe et al (25)
VTE	0.188	Lassen et al (25), errikson et al (26)
DVT	0.976	Lassen et al (25), turipe et al (25)
PE	0.024	Lassen et al (25), turipe et al (25)

of oral anticoagulants, in addition to the need for constant monitoring, will have a less financial burden for patients and health systems because the patient can use this drug himself and does not need to go to health centers and be hospitalized for injection (21).

Rivaroxaban is a specific active factor X inhibitor with excellent bioavailability and a half-life of approximately three hours, which not only releases factor Xa inhibitors but also inhibits prothrombinase and factor Xa activities with clots. Better clinical results are obtained when rivaroxaban is used three days after surgery. When its use is delayed until the third day after surgery, wound complications might be avoided. The most important advantage of this drug is its oral intake once a day. Also, other advantages of this drug are no need for constant monitoring of coagulation tests, fewer drug, and even food interactions, and fewer hemorrhagic complications compared to enoxaparin (2).

Various studies worldwide have compared the cost and effectiveness of these drugs. The results of studies in Canada indicate that rivaroxaban is more effective than enoxaparin (5). Clinical trial studies in the Netherlands and Denmark also show the same results (15, 22). On the other hand, there is no significant difference between the effectiveness of rivaroxaban compared to enoxaparin in some clinical trials (23, 24). Given the contradictory results of studies and considering different thresholds in studies, it seems necessary to conduct this study in Iran. The present study chooses rivaroxaban as an alternative to enoxaparin because the prescription of enoxaparin by Iranian clinical specialists is very common, and other alternatives are rarely prescribed. In this study, the generic type of rivaroxaban is used which is produced in Iran and prescribed in the hospitals of Iran University of Medical Sciences. It is noteworthy that the original medicine is 5 times more expensive than the generic medicine in Iran.

Messaging is increasing in Iran, and with increased demand for knee replacement, it is expected that approximately 1000 people will go to hospitals every year due to VTE after knee replacement surgery, which will impose a great economic burden on the health system (18).

Given the high outbreak of thrombolysis in Iran and the fact that new treatments can effectively prevent this disease, it seems necessary to economically evaluate the benefits and costs of drugs.

This study evaluates the economic evaluation of rivaroxaban and enoxaparin in the VTE prophylaxis in patients undergoing knee replacement surgery and seeks to

assist health system policymakers in prioritizing and optimally allocating limited health resources.

Methods

This is a descriptive-analytical study performed using a decision tree and TreeAge software. The study population consists of patients who are hospitalized after knee replacement surgery.

The research settings are ShafaYahyaieian and Rasoul Akram Hospitals in Tehran. Shafa Hospital in Tehran is selected for its exclusive specialization in orthopedics and Rasoul Akram Hospital for its specialization in embolism treatment centers.

In this study, the probabilities of events are obtained by using a systematic review of economic evaluation studies of these two drugs (Table 1).

Model

The decision tree of this study is shown in Figure 1. Patients were receiving one of the two drugs, rivaroxaban or enoxaparin after knee replacement surgery. In both strategies, after taking the drug, they either do not have any events or bleed. If they bleed, the patient will either develop venous thromboembolism, die, or be in full recovery. If they have venous thromboembolism or develop pulmonary embolism or deep vein thrombosis, that in either case is either fatal or full recovery.

Calculation of prophylaxis and treatment costs of two interventions

In this regard, 203 hospitalized cases with knee joint replacement diagnostic codes are selected to estimate the

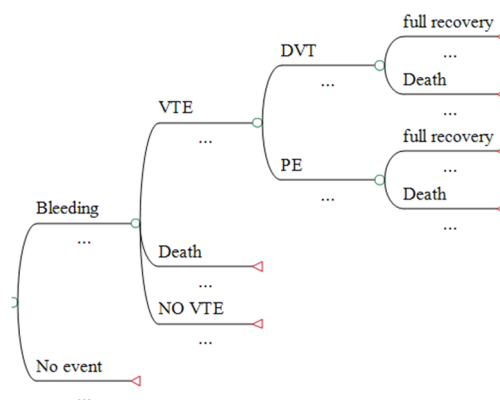

Figure 1. Decision tree

prophylaxis costs. These include all patients who were admitted to Shafa Yahyaean Hospital in Tehran in 2019. To calculate the cost of treatment in six different treatment situations, a separate sample of 300 cases is selected from Rasoul Akram Hospital. Among the 300 samples admitted to Rasoul Akram Hospital in 2020, 100 cases are related to patients who suffered from bleeding after knee replacement surgery, and 100 cases are related to patients who suffered from VTE after this surgery and 100 cases are related to patients who developed PE after the surgery.

In this study, the criterion for calculation from the perspective of the health system costs includes direct medical costs. Information on direct medical costs in this study is the cost of doctor visits, the cost of orthopedic drugs, hospital costs, diagnostic tests, and paraclinical (laboratory) procedures (Table 2).

At this stage, hospital costs are extracted through medical records, and outpatient costs are extracted through interviews with patients and consultation with clinical specialists. It should be noted that direct medical expenses are collected through the patient's medical records and medical bills. Cost calculations in this study are performed in two main steps: 1. Calculation of drug costs related to embolism prophylaxis includes all patients who have undergone knee replacement surgery (Table 3). 2. Calculation of treatment costs for all patients who have undergone knee replacement surgery and have a complication (Table 4).

Determining the clinical consequences of two interventions

In this study, effectiveness is measured through the quality-adjusted life years index (QALY). To determine the QALY, when utility is determined, then QALY is obtained by multiplying the time spent in a particular situation and the utility associated with that situation.

Finally, the cost-effectiveness of rivaroxaban compared to enoxaparin for VTE prophylaxis in knee replacement patients is evaluated using a decision tree. The time horizon is 1 year in the decision tree. Because the time horizon is 1 year, the discounting rate is not considered.

Table 2. Direct medical cost rivaroxaban versus enoxaparin

Direct medical cost	Rivaroxaban	Enoxaparin
Visit	61\$	79\$
Radiology	113\$	230\$
Doppler ultrasound	60\$	87\$
CT scan	45\$	38\$
MRI	37\$	46\$
Laboratory	89\$	90\$
Electrocardiography	4\$	4\$
Echocardiography	50\$	54\$
Nursing services	52\$	68\$

Table 3. Prevention cost rivaroxaban versus enoxaparin

Name	Rivaroxaban	Enoxaparin
Drug outpatient cost	25\$	44\$
Drug inpatient cost	95\$	142\$

Table 4. Treatment cost in different health status

Name	DVT	PE	Bleed event
Treatment outpatient cost	234\$	172\$	221\$
Treatment inpatient cost	2635\$	2715\$	5943\$

Sensitivity analysis

To increase the accuracy of the decision tree results, sensitivity analysis is performed as a one-way deterministic sensitivity analysis and probabilistic sensitivity analysis. In one-way sensitivity analysis, the effect of the value of a parameter change (e.g., cost or effectiveness) on the value of the incremental cost-effectiveness ratio is measured. To identify this parameter, a tornado diagram is drawn. This process is performed for all uncertainty parameters (such as cost and effectiveness).

It is necessary to investigate the simultaneous effect of all parameters in the model by assigning the probability distribution to the parameters (e.g., normal distribution, beta, gamma, etc.) To increase the accuracy and generalize ability of the results. Probabilistic sensitivity analysis (PSA) is used in this regard. In the PSA, the probability distribution is determined for each of the model parameters, and a scatter plot is drawn for the points of incremental cost-effectiveness ratio using the Monte Carlo simulation method and according to the place of the maximum point density, the cost-effectiveness of the compared interventions was judged using the concept of a confidence interval. After performing PSA, the cost-effectiveness acceptability curve (CEAC) is used to determine the cost-effectiveness of rivaroxaban compared to enoxaparin. This curve shows how likely the intervention would be cost-effective in exchange for a willingness to make different payments.

Results

Costs

According to international drug protocols and in consultation with Iranian clinical specialists, the patient should take one oral rivaroxaban daily for 14 days or inject one vial of enoxaparin daily for 14 days for VTE prophylaxis after knee replacement surgery. According to cost results, rivaroxaban is less expensive than enoxaparin, both in inpatient and outpatient anticoagulants. It is noteworthy that outpatient costs have been calculated according to international drug protocols and in consultation with clinical specialists, and hospitalization costs have been obtained from patients' bills.

The price of the drugs is asked from the hospital pharmacy, and according to the dosage of patients with knee replacement, their price is taken into account. The price of 10 sheets of rivaroxaban without including insurance is \$15.6 and the price of one enoxaparin without insurance is \$6.32.

Rivaroxaban and enoxaparin are also used to treat VTE. Due to the cost results, rivaroxaban is less expensive than enoxaparin in treating VTE and cost-saving.

Cost-effectiveness analysis is performed using TreeAge pro-2012. At this stage, the cost-effectiveness of rivaroxaban compared to enoxaparin for VTE prophylaxis in knee replacement patients is evaluated using the decision tree. The results of the analysis showed that the cost of rivaroxaban is \$160.97 and the quality of life is 0.85 QALY and the cost of enoxaparin is \$276.07, and the quality of life is 0.69 QALY. The difference in cost is \$115.09 and the difference in effectiveness is 0.16 QALY. The incremental

Table 5. Incremental cost-effectiveness rate rivaroxaban versus enoxaparin

Strategies	Enoxaparin	Rivaroxaban
Cost (US \$)	276.07	160.97
QALY	0.69	0.85
ICER (\$/OALY)		-720.17

cost-effectiveness rate is \$-720.17 per QALY (Table 5).

As the results of the decision tree show, rivaroxaban is more cost-effective than enoxaparin for VTE prophylaxis and is the dominant option table.

Table 5 shows the cost-effectiveness of rivaroxaban compared to enoxaparin for VTE prophylaxis after knee replacement surgery. With a cost of \$160.97 and an effectiveness of 0.85, rivaroxaban is more cost-effective than enoxaparin. The cost per QALY is \$189.40 for rivaroxaban and \$400 for enoxaparin. The results of the table above indicate that enoxaparin will reduce effectiveness by \$ 0.159 and will increase costs by \$115.09, and is therefore considered a losing option (Figure 2).

Sensitivity analysis

To increase the accuracy of the decision tree results, sensitivity analysis is performed as a one-way sensitivity analysis and probabilistic sensitivity analysis.

For one-way sensitivity analysis, first, the input parameters of the model, including costs and consequences in the upper and lower ranges, are changed and this process is performed for all uncertainty parameters (cost and consequence). The effect of changes in input parameters on the incremental cost-effectiveness ratio is examined by the tornado diagram and its graphical representation is presented in Figure 1. This diagram shows the sensitivity of the incremental cost-effectiveness ratio to a certain per-

centage of change in the initial data (cost and utility). In other words, it shows how much the incremental effectiveness cost ratio changes with a certain percentage change in the initial data. Figure 1 is obtained with a change of 20% in costs and 10% in QALY and based on its results, the most effective has resulted from the quality of life variable in the uncomplicated condition of rivaroxaban. The rate of change in costs and QALY is considered according to the inflation rate in Iran and consultation with the clinical specialists.

The final result of the analysis is shown in Figure 3.

Due to the greater weight of this variable, one-way sensitivity analysis is performed on the variable quality of life in the uncomplicated condition of rivaroxaban. The results of sensitivity analysis on the desired variable show that rivaroxaban is still considered the dominant option in different domains.

Probabilistic sensitivity analysis

Probabilistic sensitivity analysis is used to increase the accuracy of the results and generalize the ability of the findings and investigate the simultaneous effect of all parameters by assigning the probability distribution to the parameters.

In the probabilistic sensitivity diagram, the horizontal axis shows the incremental cost-effectiveness (difference in utility of two drugs), and the vertical axis shows the incremental cost (difference between the cost of two drugs). This diagram shows the simulation results of a 10,000-set. This means that by giving the beta distribution to the utility and giving the gamma distribution to the cost in TreeAge, a simulated number of 10,000 incremental cost-effectiveness ratios are obtained that are shown as small dots in the diagram. Most of the simulated incre-

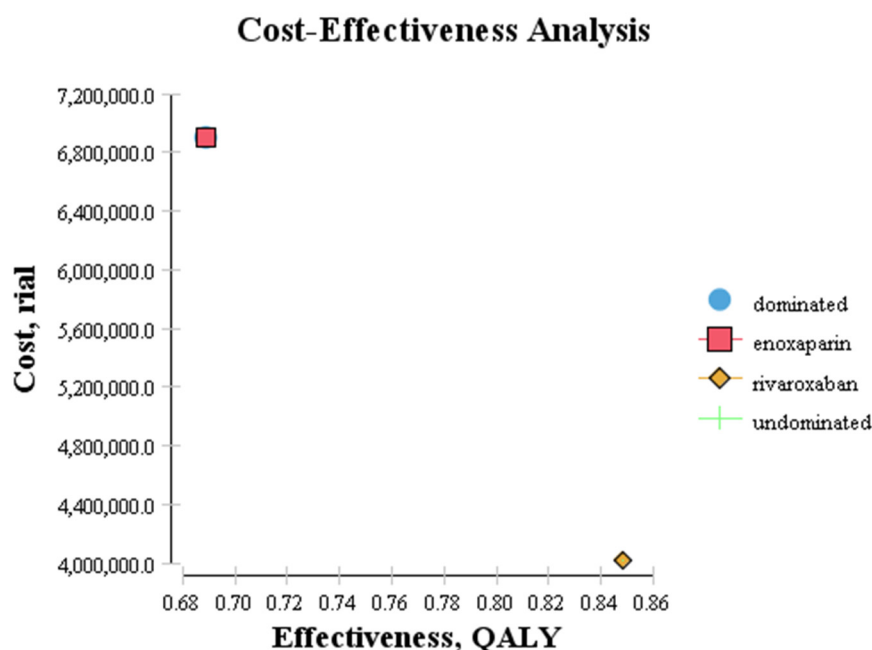

Figure 2. Cost-effectiveness map for rivaroxaban compared to enoxaparin

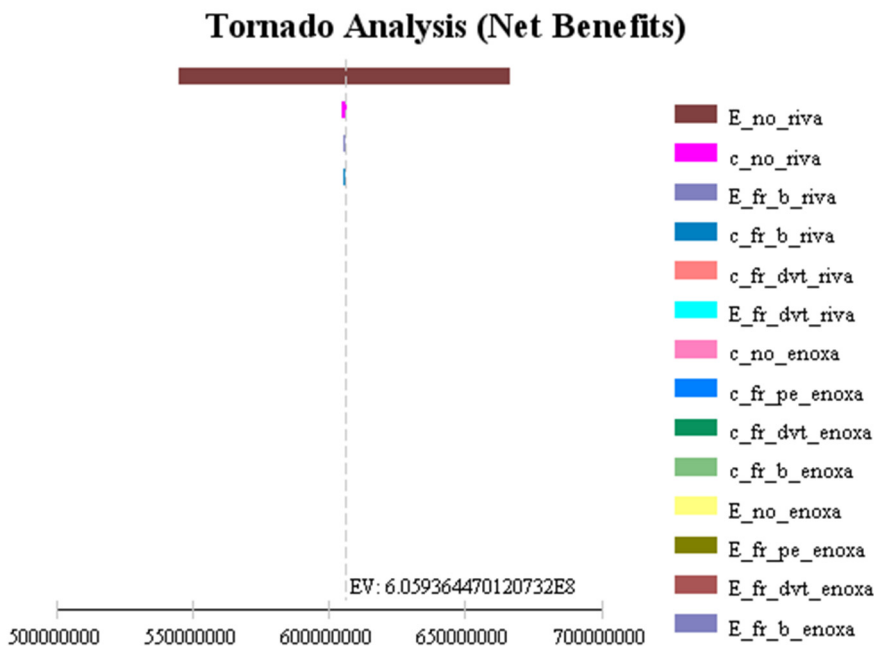

Figure 3. Tornado diagram

mental cost-effectiveness ratios indicate the validation of rivaroxaban compared to enoxaparin (Figure 4).

Results of the acceptability curve also show that the cost is effective at the level of willingness to pay \$ 10,000 for rivaroxaban compared to enoxaparin for VTE prophylaxis with a 90% probability. According to this curve, in case of an increase in willingness to pay, rivaroxaban is still more likely to be cost-effective than enoxaparin (Figure 5).

Discussion

The present study is the first cost-effectiveness study of rivaroxaban compared to enoxaparin for VTE prophylaxis in Iran. After searching the databases, no systematic re-

view study was found on the economic evaluation of rivaroxaban and enoxaparin for VTE prophylaxis after knee replacement surgery. After searching and evaluating the quality of the studies, 9 papers are included in the final analysis phase and their results are presented. Due to the lack of local data, data related to the probability of occurrence are obtained from systematic review studies.

In the second stage, considering that the study view is provided by the public sector, only direct medical costs are calculated, which is one of the limitations of our study. Different results could be obtained if other perspectives were considered and indirect costs were considered. Direct medical costs for both interventions in this study

Incremental Cost-Effectiveness, rivaroxaban v. enoxaparin

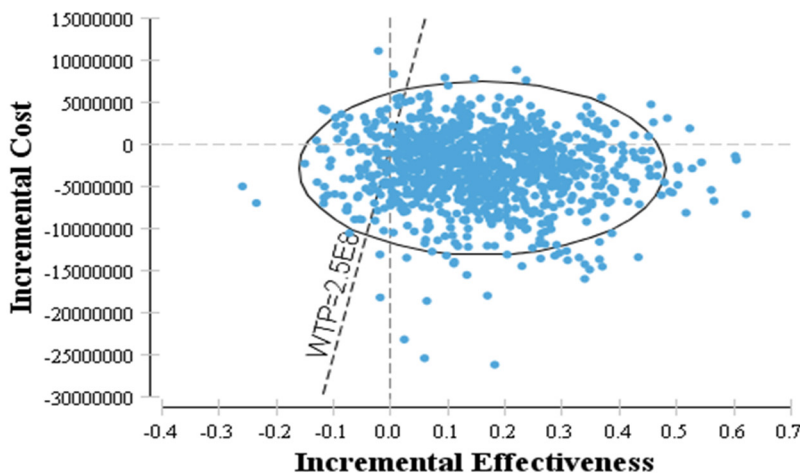

Figure 4. Results of the probabilistic sensitivity analysis of rivaroxaban compared with enoxaparin

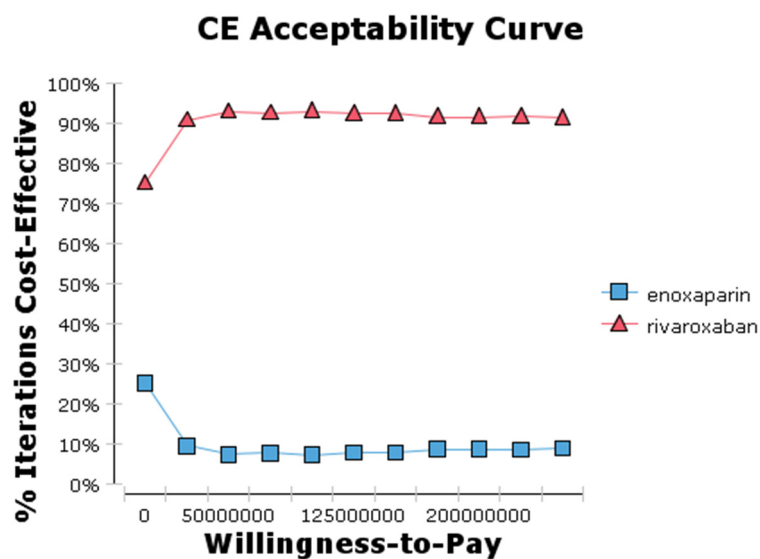

Figure 5. Acceptance curve of cost-effectiveness of rivaroxaban compared to enoxaparin

include medical visits and consultations, medications and supplies, radiology, laboratory, CT scan, ultrasonography, radiography, MRI, nursing services, and hospital hoteling cost.

For cost results in the prophylaxis phase, drug costs in hospitalized patients and outpatient drug costs are calculated. Inpatient costs in knee replacement postoperative prophylaxis for rivaroxaban \$95.35 and for enoxaparin \$138.63, and outpatient drug costs related to the VTE prophylaxis after knee replacement surgery in the present study is \$117.191 for rivaroxaban and \$182.86 for enoxaparin, which is due to the higher price of enoxaparin than rivaroxaban.

Outpatient costs are calculated according to international drug protocols and in consultation with clinical specialists, and hospitalization costs are obtained from patients' bills.

The cost findings of treatment show that the cost of VTE treatment with rivaroxaban in all health conditions is lower than the cost of treatment with enoxaparin. In the case of bleeding, 70% of the costs are related to surgery, but in other cases, most of the direct costs are related to diagnosis and drugs.

In this study, the hospitalization costs for the VTE treatment of different health conditions for patients with rivaroxaban and enoxaparin are assumed to be the same as in other foreign studies (27-33). The mean hospital stay among patients receiving rivaroxaban is 12 days and among patients receiving enoxaparin is 14 days.

In the study of the utility for other conditions due to the patient being affected by his condition, such as hospitalization in the ICU, which itself reduces the quality of life, systematic review studies are used, which is one of the limitations of our study. If questionnaires and interviews with patients could have been used for complicated situations, different results could have been obtained. The time horizon in the present study was one year and since the

disease was not reversible in different health conditions, the decision tree was used for this model. Due to the fact that the time horizon of the study was one year, the discount rate was not applied. In this study, one-way and probabilistic sensitivity analysis was performed and in all analyzes, rivaroxaban was dominant with fewer costs and more efficiency.

In this study, a generic drug produced domestically for rivaroxaban was used in comparison with enoxaparin, and foreign studies have used the original drug in their studies.

Rittenberg conducted his study in two phases: medium-term (90 days) and long-term (5 years). In this study, reducing the cost of VTE prophylaxis was one of the most important results of using rivaroxaban and although it had little effect on the VTE treatment costs, the use of rivaroxaban was reported to be more cost-effective than enoxaparin because of its cost savings and increased QALY. In patients with knee replacement surgery, rivaroxaban was dominant with a cost of \$21 and the resulting QALY 3.81 compared to enoxaparin with a cost of \$34 and 3.80 QALY. The results of the present study also showed that the cost of VTE prophylaxis with rivaroxaban was much lower than that of enoxaparin, which was not much different in the cost of treatment (30).

In a study conducted by Montreal et al., in three countries, France, Italy, and Spain, despite the different healthcare systems that existed in these countries, the results were the same and rivaroxaban was more cost-effective and increased quality of life than enoxaparin. The study showed that the results could be generalized to other European countries. The study showed that the use of rivaroxaban reduced costs by \$82, \$98 and \$219 and increased QALY by 0.0014, 0.0013 and 0.0013 in France, Italy and Spain, respectively. This analysis considered all relevant costs and clinical outcomes for postoperative and long-term periods over a five-year horizon. Also, based on probabilistic sensitivity analysis, they found that rivaroxa-

ban was the most cost-effective strategy with a threshold of \$ 725 per QALY, resulting in cost savings (34). The results of this study were consistent with the results of the present study.

In the study by Donald et al., the results showed that rivaroxaban was superior in preventing VTE at a lower cost compared to enoxaparin during the treatment period. Rivaroxaban had a cost of \$ 254 and QALY 4.1870, while enoxaparin had a cost of \$ 391 and QALY 4.1851. In this study, rivaroxaban was the predominant option. At the \$ 45,523 threshold, it outperformed enoxaparin. Rivaroxaban was the dominant option after doing probabilistic sensitivity analysis (35) and in the present study, rivaroxaban was the dominant option after sensitivity analysis.

In a study by Mac et al., rivaroxaban and dabigatran were less expensive and more effective than enoxaparin. In this study, rivaroxaban cost \$ 210 and had a QALY of 0.924 and enoxaparin cost \$ 214 and had a QALY of 0.923 was the dominant option. Rivaroxaban was also less expensive and more effective than dabigatran. After performing a probabilistic sensitivity analysis, rivaroxaban was the dominant option compared to enoxaparin at the threshold of \$ 724 (36) which was consistent with the results of our study.

In the study of Diamantopoulos et al., who analyzed the cost-effectiveness of rivaroxaban and enoxaparin, rivaroxaban was more cost-effective with an increase in QALY of \$ 0.0018 and a decrease in the cost of \$ 123 per patient compared to enoxaparin. In this study, rivaroxaban, with \$254 cost and 4.1870 QALY, was the dominant option compared to enoxaparin at \$ 377 and QALY at 4.1852. In this study, hospitalization and outpatient costs in different disease conditions were assumed to be the same. In this study, there was no significant difference in the effectiveness of these two drugs. Also, the results of probabilistic and one-way sensitivity analysis showed that rivaroxaban was still predominant over enoxaparin (5), which was also the predominant option in our study.

Results of the study by Gurzolides et al., regardless of the length of time required for treatment, have shown that rivaroxaban is a cost-effective alternative to routine care for controlling DVD and PE. In this study, patients who received rivaroxaban received 13.14 QALY in DVT and 11.99 QALY in PE, and patients who received enoxaparin received 13.12 in DVT and 11.98 QALY in PE. The results of the cost-effectiveness analysis in this study showed that with an incremental cost-effectiveness ratio of \$ 306 per QALY, rivaroxaban was more effective and less expensive than enoxaparin. After probabilistic sensitivity analysis, rivaroxaban was the dominant option with a 99% probability compared to routine care at the \$58,790 threshold (37).

In a study by Noz et al., rivaroxaban was the dominant option compared to enoxaparin. According to the findings of that study, rivaroxaban was dominant with a cost of \$ 156, with efficacy of 3.4126 QALY, over enoxaparin with a cost of \$ 364 and an efficacy of 3.4592 QALY. After sensitivity analysis, rivaroxaban was cost-effective in both knee and hip replacement compared to enoxaparin (38), which was consistent with the results of the present study.

In the study by Zindel et al., the hospital and insurance were examined. Given the type of reimbursement in the hospital, which was DRG, the hospital was reluctant to use rivaroxaban, which was less expensive and more effective, which in turn reduced hospital profits. Therefore, from the perspective of the hospital, this intervention was not cost-effective. But from the point of view of the health insurance system, rivaroxaban was cost-effective, with a cost of \$ 29 per patient, compared to enoxaparin with \$ 69 per patient (39).

A study by Jan et al., comparing the cost-effectiveness of apixaban, rivaroxaban, and enoxaparin, found that rivaroxaban had a higher cost and lower QALY than the other two drugs. The study cited the higher cost of new oral anticoagulants and the lower cost of enoxaparin in China as other reasons why enoxaparin was more cost-effective than rivaroxaban. This study reported a cost of \$ 117 and an efficiency of 4.4890 QALY for enoxaparin and a cost of \$ 152 and an efficiency of 4.4826 QALY for rivaroxaban. Finally, the study concluded that enoxaparin was cost-effective compared to other drugs (40).

In another study, Lassen et al. examined the efficacy and safety of rivaroxaban and enoxaparin in preventing knee replacement in a double-blind, randomized clinical trial. Patients received either oral rivaroxaban 10 mg daily (starting 6-8 hours after surgery) or injectable enoxaparin 40 mg daily (starting 12 hours after surgery). DVT occurred in 9 out of 908 patients receiving rivaroxaban and 24 out of 928 patients receiving enoxaparin. Accordingly, the use of rivaroxaban was associated with a 1.6% reduction in the risk of DVT following knee replacement surgery. Bleeding occurred in 0.5% of patients in both groups. They concluded that rivaroxaban was more effective than enoxaparin in VTE prophylaxis after knee replacement surgery (41).

Trip et al. also compared the efficacy and safety of rivaroxaban and enoxaparin in VTE prophylaxis after knee replacement surgery in a clinical trial. Patients received either 10 mg oral rivaroxaban or 30 mg injectable enoxaparin daily. Efficacy-related complications including VTE, PE, and death, occurred in 67 out of 965 patients receiving rivaroxaban and 97 out of 959 patients receiving enoxaparin. Accordingly, the use of rivaroxaban was associated with a 3.2% reduction in the risk of efficiency-related complications. Bleeding occurred in 0.7% of patients receiving rivaroxaban and in 0.3% of patients receiving enoxaparin. Based on these results, they concluded that rivaroxaban was significantly more effective than enoxaparin and, therefore, it was preferred over enoxaparin (42).

In a double-blind, randomized clinical trial, Erickson et al. evaluated the efficacy and safety of enoxaparin and rivaroxaban in patients following hip replacement surgery. Patients in the rivaroxaban group received 10 mg of rivaroxaban daily orally, the first dose received after surgery. Patients in the enoxaparin group received 40 mg of enoxaparin daily subcutaneously, with the first dose received the evening before surgery. The rivaroxaban group was given a placebo injection and the enoxaparin group was given a placebo pill. VTE was used to evaluate the efficacy and bleeding was evaluated for safety. It occurred

in 4 out of 1686 patients receiving rivaroxaban and 33 out of 1678 patients receiving enoxaparin. Accordingly, the use of rivaroxaban reduced the risk of VTE by 1.7%. Bleeding occurred in 6 out of 2209 patients receiving rivaroxaban and 2 out of 2224 patients receiving enoxaparin. But this difference was not significant. They concluded that the safety of rivaroxaban and enoxaparin was similar but rivaroxaban was more effective (43).

Conclusion

Due to the health resource crisis in the world, evidence-based decision-making is felt more. An economic evaluation of health interventions, especially cost-effectiveness analysis, is needed as a tool to generate this evidence. With the cost-effectiveness study, it is possible to determine which drug costs less for a certain efficacy. Thus, by expanding this treatment method and emphasizing its use in the relevant treatment centers, health system resources can be saved. The results of this study can help physicians in applying and selecting the desired and appropriate treatment intervention in addition to producing new evidence on the cost-effectiveness of new technologies in the clinical field. Evidence from the present study can also provide the necessary information for health policy in the field of rivaroxaban. An economic evaluation of drugs can help planners, including the health system and insurance organizations in allocating scarce resources, deciding on reimbursements, providing clinical guidance on the use of these drugs, and strategically purchasing these interventions.

The results of the present study showed that rivaroxaban reduced the cost and increased the quality of life in people undergoing knee replacement surgery. Due to the fact that rivaroxaban was taken orally and did not require constant monitoring, it would cost less for the patient and the health system, and its use as a thromboprophylactic drug after surgery was preferred.

Conflict of Interests

The authors declare that they have no competing interests.

References

- Samavat T, Hojatzadeh A, Shams M, Afkhami A, Mahdavi A, Bashfi Sh, et al. Ways of prevention and control of cardiovascular diseases. Tehran. Press Javan. 2013. [In Persian]
- Aslan A, Khorami R, Rezaii J, Godarzi M, Abbasi Dolatabadi Z. Drug updates for prevention and treatment of venous thromboembolism in orthopedic surgeries. *J Cardiovasc Nurs*. 2017;6(2):66-73. [In Persian]
- Beckman MG, Abe K, Barnes K, Bartman B, Brady PJ, Hooper WC. Strategies and partnerships toward prevention of healthcare-associated venous thromboembolism. *J Hosp Med*. 2016;11(2):5-7.
- Le Sage S, McGee M, Emed JD. Knowledge of venous thromboembolism (VTE) prevention among hospitalized patients. *J Vasc Nurs*. 2008;26(4):109-17.
- Diamantopoulos A, Lees M, Wells PS, Forster F, Ananthapavan J, McDonald H. Cost-effectiveness of Rivaroxaban versus Enoxaparin for the prevention of postsurgical venous thromboembolism in Canada. *J Thromb Haemost*. 2010;10(10):760-70.
- Glynn RJ, Rosner B. Comparison of risk factors for the competing risks of coronary heart disease, stroke, and venous thromboembolism. *Am J Epidemiol*. 2005;162(10):975-82.
- Hassani A, Gholami K, Hajhoseintalasaz A, Mohebi N, Hassani E. Enoxaparin utilization evaluation in a cardiovascular teaching hospital.

- Urmia Med J. 2014;25(3):241-6. [In Persian]
- Geersing G, Zuithoff N, Kearon C, Anderson D, Ten Cate-Hoek A, Elf J, et al. Exclusion of deep vein thrombosis using the Wells rule in clinically important subgroups: Individual patient data meta-analysis. *BMJ*. 2014;348:g1340.
- Geerts WH, Pineo GF, Heit JA, Bergqvist D, Lassen MR, Colwell CW, et al. Prevention of venous thromboembolism: The seventh ACCP Conference on Antithrombotic and Thrombolytic Therapy. *Chest*. 2004;126(3):S338-S400
- Beckman MG, Hooper WC, Critchley SE, Ortel TL. Venous thromboembolism: A public health concern. *Am J Prev Med*. 2010;38(4):S495-S501.
- Ruppert A, Lees M, Steinle T. Clinical burden of venous thromboembolism. *Curr Med Res*. 2010;26(10):2465-73.
- Cohen AT, Agnelli G, Anderson FA, Arcelus JJ, Bergqvist D, Brecht JG, et al. Venous thromboembolism (VTE) in Europe. *J Thromb Haemost*. 2007;98(10):756-64.
- Jha AK, Larizgoitia I, Audera-Lopez C, Prasopa-Plaizier N, Waters H, Bates DW. The global burden of unsafe medical care: Analytic modelling of observational studies. *BMJ Qual Saf*. 2013;22(10):809-15.
- Konstantinides SV, Torbicki A, Agnelli G, Danchin N, Fitzmaurice D, Galie N, et al. Corrigendum to: 2014 ESC Guidelines on the diagnosis and management of acute pulmonary embolism. *Eur Heart J*. 2015;36(39):2666-69.
- Heisen M, Treur MJ, Heemstra HE, Giesen EB, Postma MJ. Cost-effectiveness analysis of Rivaroxaban for Treatment and secondary prevention of venous thromboembolism in the Netherlands. *J Med Econ*. 2017;20(8):813-24.
- House of Commons Health Committee. The prevention of venous thromboembolism in hospitalised patients. London: The Stationery Office, 2005. Report No: HC 99.
- Centers for Disease Control and Prevention (CDC). Venous thromboembolism in adult hospitalizations-United States, 2007-2009. *MMWR. Morbidity and Mortality weekly report*. 2012;61(22):401-4.
- Sharif-Kashani B, Mohebi-Nejad A, Abootorabi S-M. Estimated prevalence of venous thromboembolism in Iran: Prophylaxis still an unmet challenge. *Tanaffos Respir*. 2015;14(1):27-33.
- Habibzadeh H, Rezaeipour N, Khalkhali H, Safari B, Mohammadi A. The effect of care plan based on nutrition and exercise on deep vein thrombosis in patients undergoing lower limb orthopedic surgery in Urmia Imam Khomeini Hospital in 2012. *J Urmia Nurs Midwifery Fac*. 2013;11(9):680-7. [In Persian]
- Chotanaphuti T, Ongnamthip P, Silpipat S, Foojareonyos T, Roschan S, Reumthantong A. The prevalence of thrombophilia and venous thromboembolism in total knee arthroplasty. *J Med Assoc Thai*. 2007;90(7):1342-7.
- Budhiparama NC, Abdel MP, Ifran NN, Parratte S. Venous thromboembolism (VTE) prophylaxis for hip and knee arthroplasty: Changing trends. *Curr Rev Musculoskelet Med*. 2014;7(2):108-16.
- Lassen MR, Ageno W, Borris LC, Lieberman JR, Rosencher N, Bandel TJ, et al. Rivaroxaban versus enoxaparin for thromboprophylaxis after total knee arthroplasty. *N Engl J Med*. 2008;358(26):2776-86.
- Rickett AL, Stewart DW, Wood RC, Cornett L, Odle B, Cluck D, et al. Comparison of postoperative bleeding in total hip and knee arthroplasty patients receiving Rivaroxaban or Enoxaparin. *Ann Pharmacother*. 2016;50(40):270-5.
- Li J, Jing J, Zhou Y, Yao Y, Zhan J. Comparison of Rivaroxaban and Enoxaparin on blood loss after total knee arthroplasty. *Zhongguo Xiu Fu Chong Jian Wai Ke Za Zhi*. 2014;28(1):26-9.
- Turpie AG, Lassen MR, Eriksson BI, Gent M, Berkowitz SD, Misselwitz F, et al. Rivaroxaban for the prevention of venous thromboembolism after hip or knee arthroplasty. *J Thromb Haemost*. 2011;105(03):444-53.
- Eriksson BI, Borris LC, Friedman RJ, Haas S, Huisman MV, Kakkar AK, Bandel TJ, Beckmann H, Muehlhofer E, Misselwitz F, Geerts W. Rivaroxaban versus enoxaparin for thromboprophylaxis after hip arthroplasty. *N Engl J Med*. 2008;358(26):2765-75.
- Iyengar S, Greenhouse JB. Sensitivity analysis and diagnostics. *Handbook of research synthesis and meta-analysis. Handbook of research synthesis and meta-analysis*. 2009:417-33.
- Hatmi Z, Tahvildari S, Motlag AG, Kashani AS. Prevalence of coronary artery disease risk factors in Iran: a population based survey. *BMC Cardiovasc Disord*. 2007;7(1):32-43

29. Rasanen P, Paavolainen P, Sintonen H, Koivisto AM, Blom M, Ryyanen OP, et al. Effectiveness of hip or knee replacement surgery in terms of quality-adjusted life years and costs. *Acta Orthopaedica*. 2007;78(1):108-15.
30. Rytberg L, Diamantopoulos A, Forster F, Lees M, Fraschke A, Bjorholt I. Cost-effectiveness of Rivaroxaban versus Heparins for prevention of venous thromboembolism after total hip or knee surgery in Sweden. *Expert Rev. Pharmacoeconomics Outcomes Res*. 2011;11(5):601-15.
31. Tanaray B, Eslami M, Jahanzad I, Salehi M, Emami M. Relationship of plasma level of NT-ProBNP with development of AF in CABG patients. *Tehran Univ Med J*. 2010;68(7):384-90.
32. Nikfar S, Kebriaeezadeh A, Dinarvand R, Abdollahi M, Sahraian M-A, Henry D, et al. Cost-effectiveness of different interferon beta products for relapsing-remitting and secondary progressive multiple sclerosis: Decision analysis based on long-term clinical data and switchable treatments. *Daru J Pharm Sci*. 2013;21(1):50.
33. Hutubessy R, Chisholm D, Edejer TT. Generalized cost-effectiveness analysis for national-level priority-setting in the health sector. *Cost Eff Resour Alloc: C/E*. 2003;1(1):8.
34. Monreal M, Folkerts K, Diamantopoulos A, Imberti D, Brosa M. "Cost-effectiveness impact of rivaroxaban versus new and existing prophylaxis for the prevention of venous thromboembolism after total hip or knee replacement surgery in France, Italy and Spain." *J Thromb Haemost*. 2013;110(11): 987-994.
35. McDonald H, Diamantopoulos A, Wells P, Lees M, Folkerts K, Forster F, et al. "Cost-effectiveness of rivaroxaban in the prevention of venous thromboembolism: a Canadian analysis using the Ontario Ministry of Health perspective." *J Med Econ*. 2012;15(5):817-828.
36. McCullagh L, Tilson L, Walsh C, Barry M. A cost-effectiveness model comparing rivaroxaban and dabigatran etexilate with enoxaparin sodium as thromboprophylaxis after total hip and total knee replacement in the Irish healthcare setting. *Pharmacoeconomics*. 2009;27(10):829-46.
37. Gourzoulidis G, Kourlaba G, Kakisis J, Matsagkas M, Giannakoulas G, Gourgoulis KI, et al. Cost-effectiveness analysis of rivaroxaban for treatment of deep vein thrombosis and pulmonary embolism in Greece. *Clin Drug Investig*. 2017;37(9):833-44.
38. Neves JR, Folkerts K, Umbelino S, Santos IF. Cost-effectiveness of rivaroxaban compared with enoxaparin for the prevention of venous thromboembolism in adult patient undergoing elective hip or knee replacement surgery in Portugal. *Rev Port Farmacoter*. 2014;2(6):16-23.
39. Zindel S, Stock S, Müller D, Stollenwerk B. A multi-perspective cost-effectiveness analysis comparing rivaroxaban with enoxaparin sodium for thromboprophylaxis after total hip and knee replacement in the German healthcare setting. *BMC Health Serv Res*. 2012;12(1):192.
40. Yan X, Gu X, Xu Z, Lin H, Wu B. Cost-effectiveness of different strategies for the prevention of venous thromboembolism after Total hip replacement in China. *Adv Ther*. 2017;34(2):466-80.
41. Minns Lowe CJ, Barker KL, Dewey M, Sackley CM. Effectiveness of physiotherapy exercise after knee arthroplasty for osteoarthritis: systematic review and meta-analysis of randomised controlled trials. *BMJ*. 2007; 335: 812
42. Tayton ER, Frampton C, Hooper GJ, Young SW. The impact of patient and surgical factors on the rate of infection after primary total knee arthroplasty: an analysis of 64 566 joints from the New Zealand Joint Registry. *Bone Joint J*. 2016;98(3):334-40.
43. Leopold SS. Minimally invasive total knee arthroplasty for osteoarthritis. *N Engl J Med*. 2009;360(17):1749-58.